

METRO SIGN STANDARDS

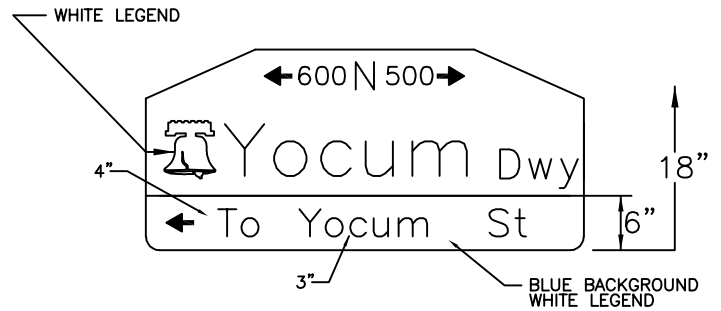
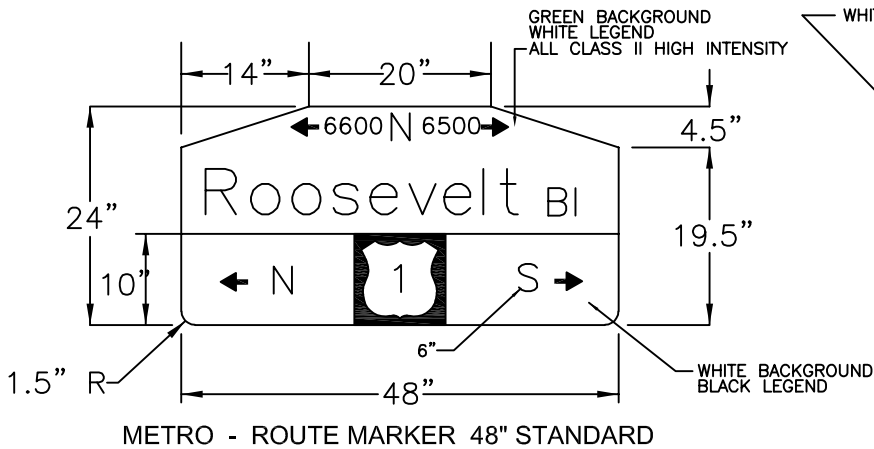
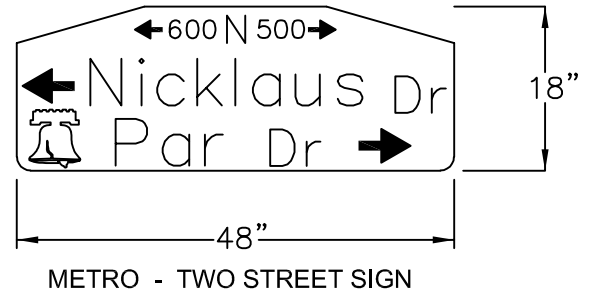
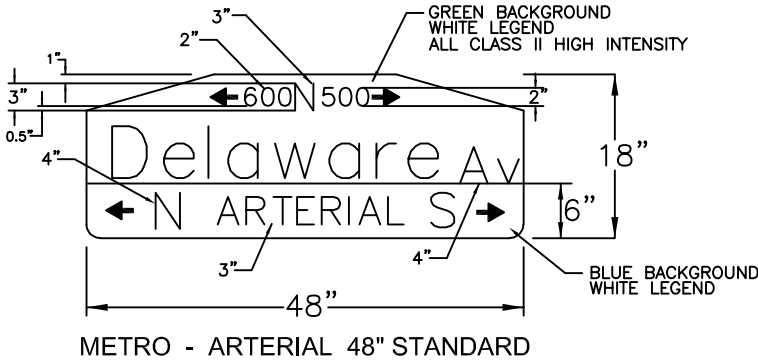
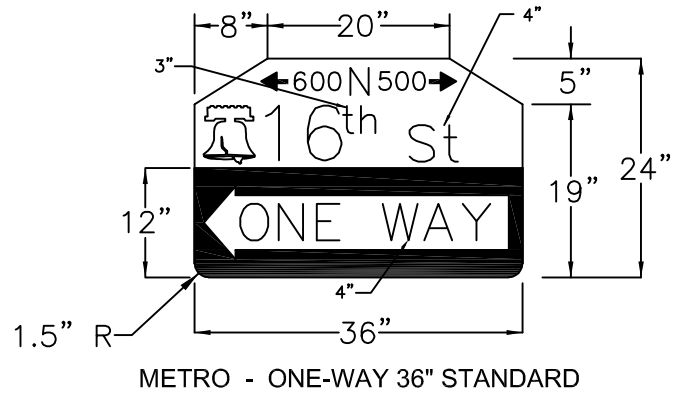
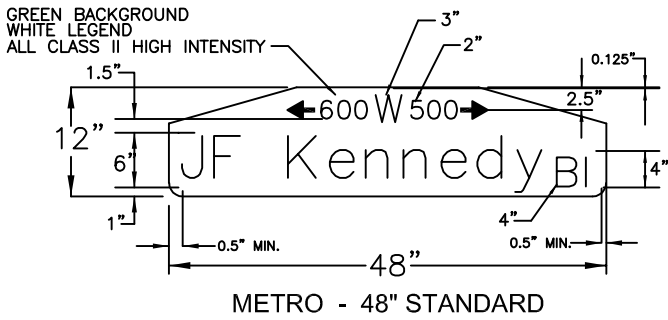

SIZE AND LAYOUT OF SIGNS

- 36 or 48 inches dependent on the number of letters in street name
- All Letters and numbers count as one unit size except for letters:
 "i" = 1/2 unit size
 "A" = 1 1/2 unit size
 "M" = 1 1/2 unit size
 "W" = 1 1/2 unit size
 "Y" = 1 1/2 unit size
- "Space" between 2 words equals 1 (one) letter
- Disregard "st", "nd", "rd" and "th" of numbered streets when determining size.
- Font shall be Highway Gothic FHWA Standard Alphabets Font light street series

DESIGNATION ABBREVIATIONS

DESIGNATION	ABBREVIATION	DESIGNATION	ABBREVIATION
ALLEY	AL	PARKWAY	PW
AVENUE	AV	PIKE	PK
BOULEVARD	BL	PLACE	PL
CIRCLE	CR	PLAZA	PZ
COURT	CT	ROAD	RD
DRIVE	DR	ROW	RW
DRIVEWAY	DW	STREET	ST
LANE	LA	TERRACE	TR
LINE	LN	WALK	WK
MEW	MW	WAY	WY

DETERMINING SIZE

- Use 48" sign for all arterials and numbered highways signs.
- All Lettered Streets:
 - 36 inch sign
 - Spell out "Street"
 - Do not use Liberty bell
- All Numbered Streets:
 - 36 inch sign
 - Abbreviate designation
 - Use Liberty bell
- 3 to 4 Letters in street name:
 - 36 inch sign
 - Abbreviate designation
 - Use Liberty bell
- 5 Letters in street name:
 - 36 inch sign
 - Use Abbreviations
 - Do not use Liberty bell
- 6 to 7 Letters in street name:
 - 48 inch sign
 - Use Abbreviations
 - Use Liberty bell
- 8+ Letters in street name:
 - 48 inch sign
 - Use Abbreviations
 - Do not use Liberty bell

CITY OF PHILADELPHIA

DEPARTMENT OF STREETS

METRO STREET NAME

DATE 4/11/14 SHEET 1 OF 2

REVISED 10/24/16

APPROVED: V.L.F.

SN0101

METRO SIGN DRILL HOLE STANDARDS

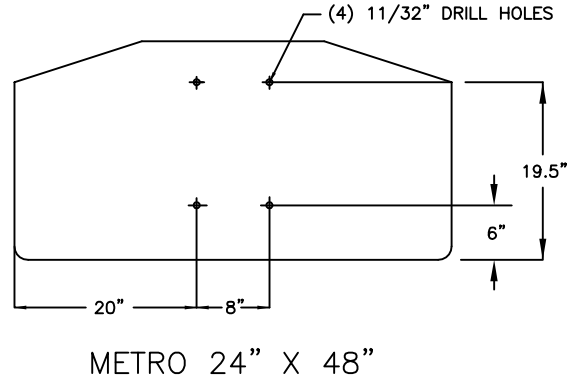
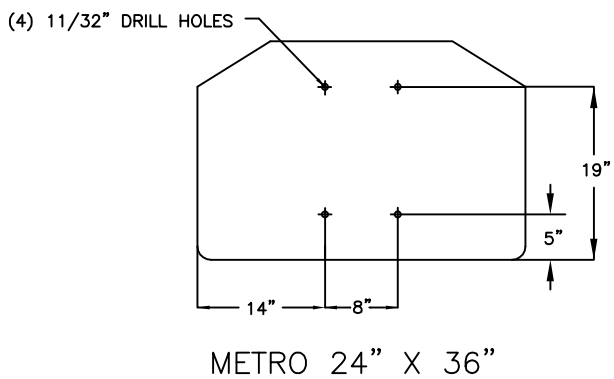
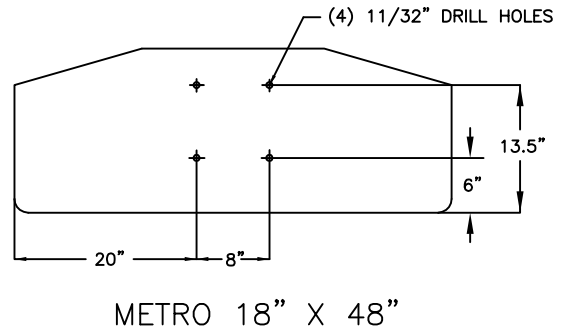
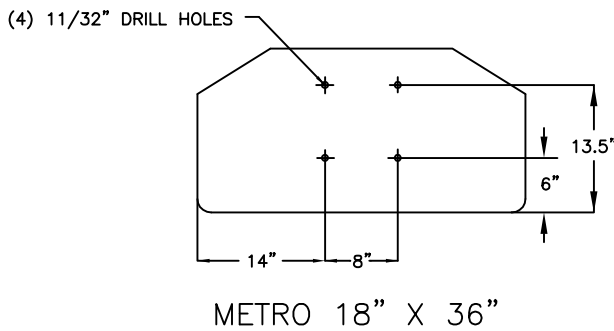
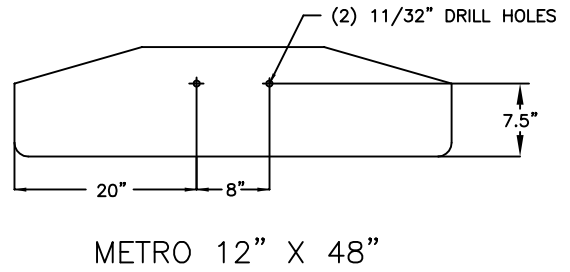
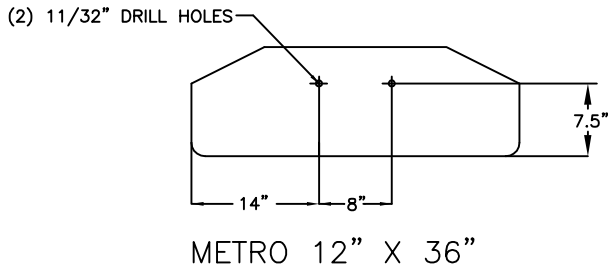

<i>CITY OF PHILADELPHIA</i>			
DEPARTMENT OF STREETS			
METRO STREET NAME			
DATE	4/11/14	SHEET 1 OF 2	
REVISED	3/01/15		
APPROVED: V.L.F.			
			SN0101